

Crane Boom-Length-and-Angle Wireless Measurement Sensor

Features

- Cable reel with 140 ft. (42 m) of wire rope to measure length
- Length resolution: 0.07 ft. (22 mm)
- Length accuracy: 0.07 ft. (22 mm)
- Angle resolution: 0.1°
- Angle accuracy: typical: 0.2°
- Angle range (GS112): -90° to +130°
- Angle range (GS112-02): 0° to 360°
- Measurement is optimized for crane movements; both the boom angle and the boom length are measured four times per second.
- The GS112 can be installed on either side of the main boom; the sensor automatically rights itself.
- Radio range with line of sight: 4000 ft. (1300 m)
- Operates with one 'D' cell battery lithium 3.6V or alkaline 1.5V.
- 1 to 2 years battery life for typical applications
- ISM license free radio; wavelength and modulation optimized for radio communication in industrial environments.
- Temperature range: -30°C to 65°C (-22°F to 150°F)
- Temperature compensated
- Potted electronics for increased water protection
- Remote angle level adjustment from compatible cab mounted display

Applications

Measurement of crane boom length and of crane boom angle to horizontal. The wire rope is fixed at the boom tip for the complete boom length measurement.

General Description

The cable reel has more than 140ft. (42 m) of extendable, spring loaded, wire rope. The extremity of the wire rope should be fixed to the extremity of the length to be measured. The cable reel ships with an anchor and cable guides.

The transmitter box on top of the cable reel houses the battery, the radio transmitter and the solid state accelerometer-based angle sensor.

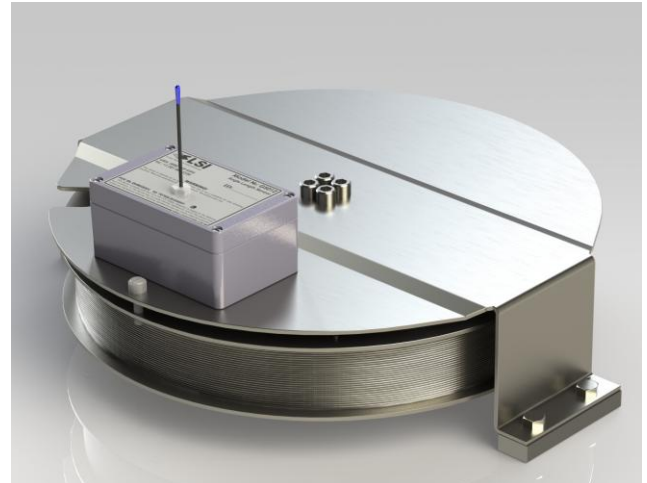

Cable reel p/n GS112

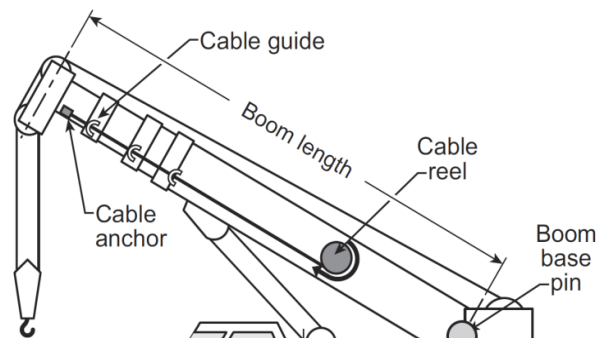

Figure: cable reel installation on the main boom for the measurement of crane boom length

Table of Contents

Features	1
Applications	1
General Description	1
Table of Contents	2
Ordering Information	2
Specifications	3
Absolute Maximum Ratings	3
Certifications	3
Application Notes	4
Dimensions and Installation	4
Materials:	4

Ordering Information

Model	Description
GS112	Cable reel with transmitter for length (140 ft.) and angle
GS112-02	Cable reel with transmitter for length (140 ft.) and 360° angle. Side of boom for installation must be specified when ordering (default: left). Typically used on knuckle booms.
GS112-CE	GS112 CE certified, with radio frequency suitable for Europe, most of Asia and Middle East
TC103-B	Replacement Cable
TA011	Replacement sensor antenna
PA111	Replacement rod cable guide
PA113	Anchor for wire rope end
PE243	Adaptation kit to install a GS112 on existing LS101 weld pads

Other related part numbers:

QC024: cable reel wire rope clamp (McMaster № 5513T11)



GS112

Specifications

Parameter	Test Condition	Min	Typ	Max	Unit
Angle					
Resolution			0.1		Degree
Accuracy			0.3		Degree
Length					
Resolution			0.07 (22)		ft. (mm)
Accuracy			0.07 (22)		ft. (mm)
Radio Power					
	GS112	0.013 11	0.016 12	0.020 13	W dBm
Radio Frequency					
North American version	GS112	902	916	928	MHz
European version	GS112-CE	868		870	MHz
Battery life (depends on usage)					
	'D' cell lithium	12	24	28	Month
	'D' cell alkaline	8	12	16	Month
Other					
Weight	GS112		46 (21)		lb (kg)

Absolute Maximum Ratings

Parameter	Test Condition	Min	Typ	Max	Unit
Temperature range	Operating	-30*		+65	°C
		-22*		+150	°F

*The GS112 will work below -30°C (-22°F), but the cable may rewind slowly when the boom is retracted.

Certifications

Safety :	IEC 61010-1
EMC :	EN 301 489-3 V1.4.1 (2002-08)
FCC :	Part 15 Subpart C, 247
I.C.	Industry Canada
CE version :	
	Wireless : EN 300 220-3 V1.1.1 (2000-09)

GS112

Application Notes

The angle sensor in the GS112 automatically detects on which side of the boom it is installed when the boom angle is less than 45° to horizontal. For knuckle booms and other applications where the boom angle may go beyond the -90° to +130° range of the GS112, the GS112-02 with 360° angle sensor should be used. Left or right side installation must be specified when ordering the GS112-02.

Dimensions and Installation

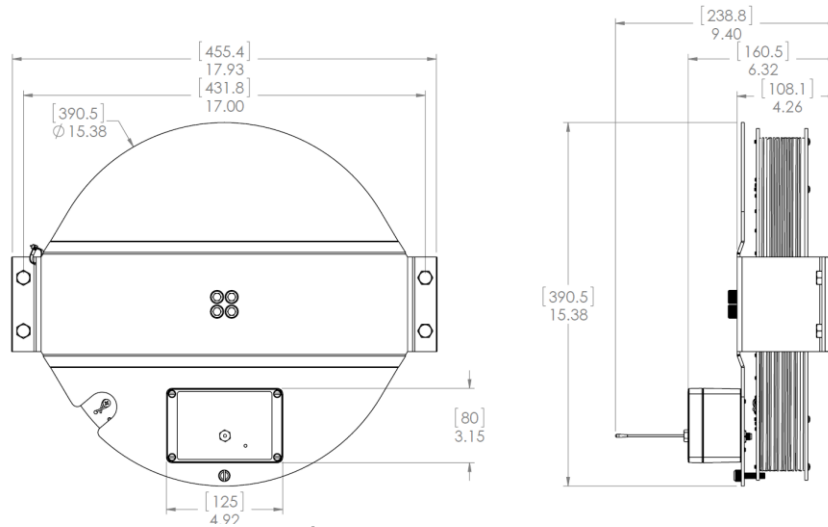

Cable reel (not to scale)

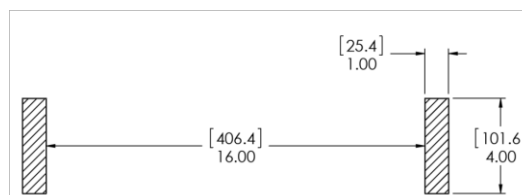

Weld pads foot print (not to scale)

Units are in inches [millimeters]

Cable reel placement: find a clear mounting position on the cab side of the first (lower) section of the main boom. The mounting position should be close to the base of the boom; at least 10 ft. (3 m) from the tip of the first section and where the cable reel won't obstruct free boom movement at all boom angles and slew positions. Furthermore, the reel must be placed such that the cable has a clear straight line to the end of the last section at all boom lengths.

Mount the welding tabs. They must be placed parallel to each other, 16 in. apart. Install the tabs such that they create a level mounting position in line with the boom when horizontal (0°). Correct alignment of the first guide is important to ensure orderly winding of the cable on the reel. Install the other guides at the end of each of the intermediate sections and the anchor at the end of the last section. All guides must be aligned so as to permit unobstructed movement of the cable. Proceed with length calibration.

The angle sensor is pre-calibrated and temperature compensated; see the installation section in the user manual for details.

Materials:

The cable reel is entirely made of stainless steel (AISI 304) with sealed bearings and a stainless steel wire. The transmitter is made of powder coated aluminum.